

- 华南办事处  
电话: 13940069968  
South China office  
Tel: 13940069968
- 华东办事处  
电话: 18602456256  
East China office  
Tel: 18602456256
- 德州办事处  
电话: 13940437228  
Dezhou office  
Tel: 13940437228
- 外贸部  
电话: 86-024-23780807-717, 86-024-83786420  
邮箱: zhangruiyan@sylg.cn  
FOREIGN TRADE CENTER  
Tel: 86-024-23780807-717, 86-024-83786420  
E-mail: zhangruiyan@sylg.cn

# SHENYANG BLUELIGHT

沈阳蓝光，伴你飞翔  
DRIVE THE FUTURE



[HTTP://WWW.SYLG.CN](http://www.sylg.cn)

2020年1月修订

Revised January 2020

样本信息仅供参考

Sample Information For Reference Only

沈阳蓝光驱动技术有限公司

电话: 024-83863349

地址: 沈阳市浑南新区世纪路 37 号

邮编: 110179

Shenyang Bluelight Drive Technology Co.,Ltd.

TEL: 024-83863349

ADD: No.37 Shiji Road, Hunnan New District,  
Shenyang, China ZIP: 110179

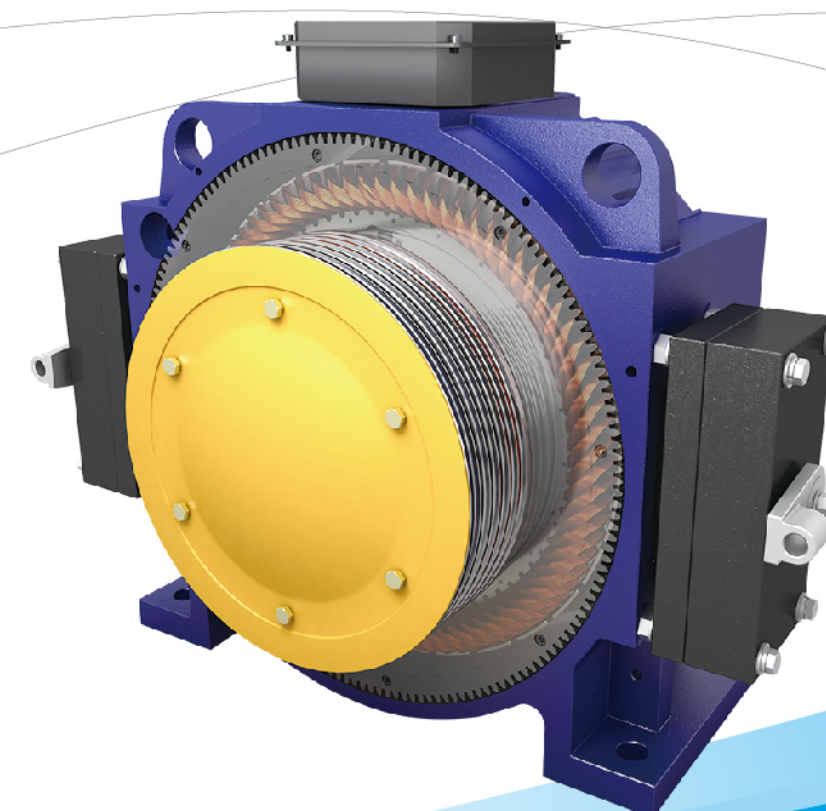



## 公司简介

- 沈阳蓝光集团成立于1989年，是专业从事电梯控制系统和永磁同步无齿轮电梯曳引机开发、生产的高科技企业。是中国电梯协会理事单位、ISO9001认证企业。
- 沈阳蓝光驱动技术有限公司在佛山及苏州均建有生产基地，其中佛山厂区5千平方米，年产2万台；苏州厂区1万平方米，年产3万台。
- 沈阳蓝光从1998年开始永磁同步无齿轮电梯曳引机产品的研制开发工作，组成了由两名电机学博士为主的课题组，投入大量人力、物力，先后同国内高校和国外知名企业开展技术合作，于2000年10月研制成功首台永磁同步无齿轮电梯曳引机并投入试运行。此后又经过多次重大技术、工艺改进，于2001年7月率先在国内通过国家电梯质量检测中心检验，并取得认证证书，产品投入批量生产。沈阳蓝光获得了永磁同步无齿轮电梯曳引机多项国家专利，拥有该项产品技术的全部自主知识产权。
- 到目前为止，蓝光集团生产的永磁同步无齿轮电梯曳引机产品在全国各地被广泛使用，部分产品远销到欧洲、美洲、韩国、日本、台湾、中东、东南亚等国家和地区。由于蓝光曳引机具有运行噪音低、振动小、运行舒适平稳等特点，深受广大电梯制造厂商的青睐。



沈阳总部  
Shenyang Head Quarters



苏州工厂  
Suzhou Plant



佛山工厂  
Foshan Plant



抚顺工厂  
Fushun Plant



浙江工厂  
Zhejiang Plant

## About us

- Established in 1989, Bluelight is a leading manufacturer of elevator control systems and gearless permanent magnet synchronous machines. It is member of China Elevator Association and an enterprise certified by ISO9001.
- Shenyang BlueLight has also built production base in Foshan and Suzhou area. Foshan factory has floor space of 5,000 m<sup>2</sup> with annual production capacity 20,000 units. Suzhou factory has floor space of 10,000 m<sup>2</sup> with annual production capacity 30,000 units.
- From 1998, Shenyang Bluelight started development of gearless permanent magnet synchronous machines. With a R&D team leading by two doctors experts in motor, Bluelight cooperated constantly with domestic universities, overseas well-known companies for exchange of technology and successfully developed the first gearless permanent magnet synchronous machines in October, 2000. After several technical improvements, Bluelight passed the national EMC testing in July, 2001 and successfully obtained certification. Meanwhile, the machines had been launched into mass production. Shenyang Bluelight has granted several patents of gearless permanent magnet synchronous machines and owned all the knowledge property rights.
- Nowadays, Bluelight gearless machines are widely used in China and some of the products have been sold to Europe, America, Korea, Japan, Taiwan, Middle East, Southeast Asia etc. Relying on the excellent characteristics such as low noise, low vibration, smooth and comfortable running etc., Bluelight gearless machines are being recognized by more and more elevator manufacturers.



# 曳引机选型表

● **WYT-T 永磁同步曳引机**  
WYT-T PM TRACTION MACHINE

----- 01/06

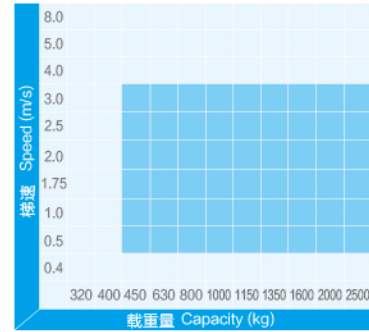

● **WYT-L 永磁同步曳引机**  
WYT-L PM TRACTION MACHINE

----- 07/09

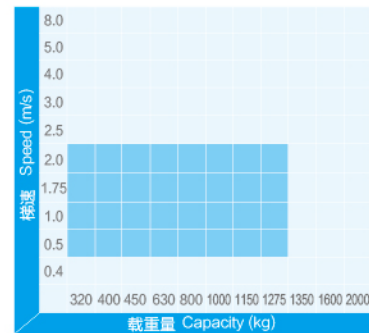

● **WYT-F 永磁同步曳引机(钢带别墅梯)**  
WYT-F PM TRACTION MACHINE(BELT VILLA)

----- 10

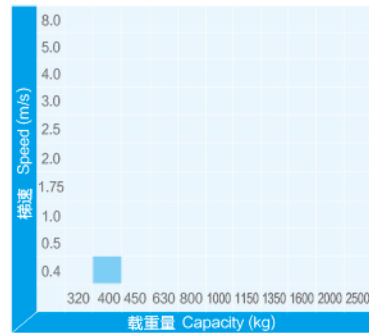

● **WYT-U 永磁同步曳引机**  
WYT-U PM TRACTION MACHINE

----- 11/12

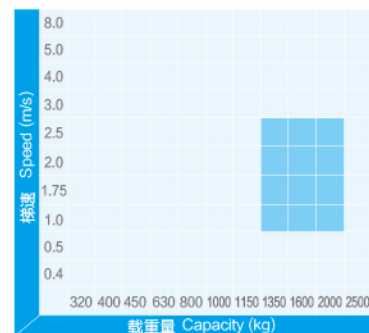

● **WYT-V 永磁同步曳引机(1:1悬挂比)**  
WYT-V PM TRACTION MACHINE(1:1 ROPING)

----- 13/14

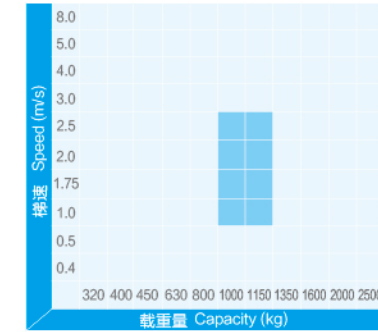

● **WYT-H 永磁同步曳引机**  
WYT-H PM TRACTION MACHINE

----- 15/16

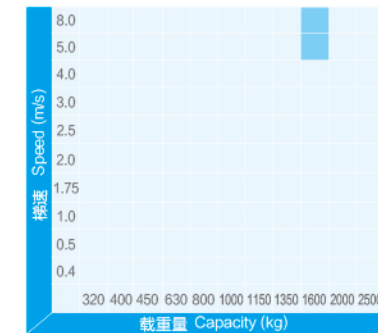

● **WYT-Y 永磁同步曳引机**  
WYT-Y PM TRACTION MACHINE

----- 17/19

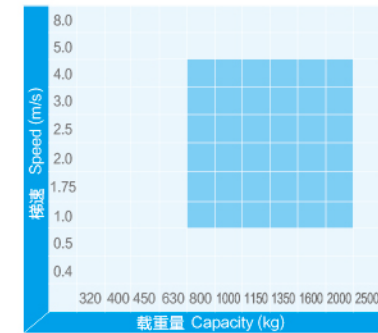

## MACHINE TYPE RECOMMENDATION TABLE

# WYT-T

## 永磁同步曳引机

### PM Traction Machine

WYT-T系列是我司主力推出的经典款外转子永磁同步曳引机。此系列经过10余年的不断改善，产品质量非常稳定，性能指标国内领先，产品覆盖范围极广，成为现在高性能电梯的首选产品。

WYT-T series outer rotor PMS machine is Blueight's most popular product. After 10 years of continuous improvement, this series product has high quality standard, with superior performance, and can cover wide range of elevator application. It is your first choice for high performance elevator.



#### 主机技术参数 (Parameter of Traction Machine)

额定电压 (Voltage) : AC380V  
 悬挂比 (Roping) : 2: 1  
 钢丝绳绕法 (Wrap) : 单绕 (Single)  
 额定载重量 (Capacity) : 450kg~2500kg  
 轿厢速度 (Speed) : 0.5m/s~2.5m/s  
 防护等级 (Protection Grade) : IP41  
 绝缘等级 (Ins. Class) : F  
 曳引机极数(Traction machine pole): 30  
 启动频次(次/小时, Stars per hour): 240  
 工作制(Rating): S5-40%

#### 特点 (Features)

- 合理的机械结构设计，轴负荷大，运行安全系数高；
- 高效率、高转矩密度设计，优化的极槽配合；
- 主机运行平稳，噪音低，振动小；
- 轿厢速度、载重量覆盖广；
- 采用无闸臂块式制动器，响应快，可靠性高。
- Optimized mechanical structure design, high shaft load, high operating safety factor;
- High efficiency, high torque density design and optimized pole slot coordination;
- Machine run smoothly, with low noise & small vibration;
- This series covers wide range of elevator speed & capacity.
- Use block type armless brake, it has fast response time & high reliability.

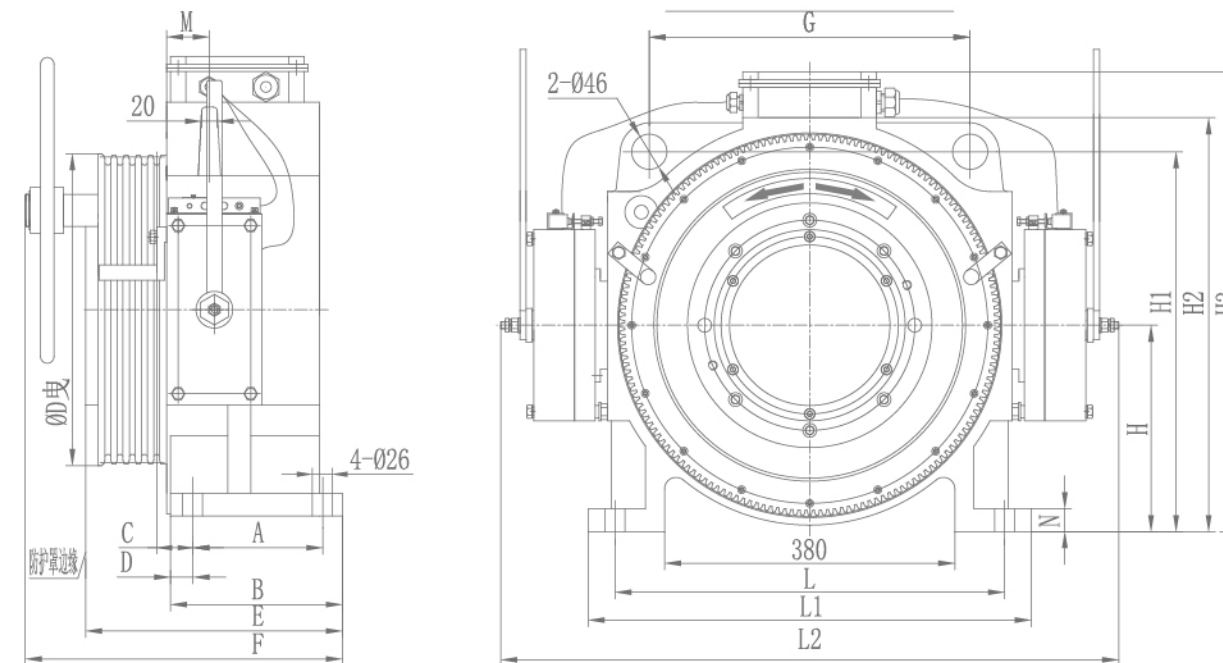

外观尺寸图 | Outline drawing

#### 制动器技术参数 (Parameter of Brake)

型号 (Model) : BLB      绝缘等级 (Ins.Class) : F      额定电压 (Voltage) : DC110V  
 额定电流 (Current) :

系列 Series	型号 Model	梯速(m/s) Speed	载重代号 Capacity code	额定电流 Current
WYT-T		0.5~2.0	A, B, AL, AS, BS, CS, DS(450kg~1000kg)	1.1A
			C, D, E, BL, CL, DL (630kg~1150kg)	1.3A
	0.5~3.0	C, D, E, CL, DL, EL(800kg~1150kg)	1.6A	
	0.5~1.75	F, FL, G, GL,H(1275kg~1600kg)	1.6A	
	0.5~2.0	C, D, E, F (1275kg~2000kg)	1.6A	
	0.5~2.5	CL, DL, EL(1275kg~1600kg)	1.98A	
		0.5~2.0	G(2500kg)	1.98A
		0.5~2.5	FL(2000kg)	



## WYT-T外转子轻载高性能系列

### WYT-T Outer Rotor Light load High Performance Series

推荐提升高度(Height): ≤80m

型号 Model	规格 Type	载重 Capacity (kg)	轿厢速度 Speed (m/s)	曳引轮直径 Sheave (mm)	槽数 Num	绳径 (mm)	槽间距 Pitch (mm)	安装尺寸 Dimension(mm)																					
								额定电流 Current (A)	额定转速 Motor Speed (rpm)	额定频率 Frequency (Hz)	额定功率 Power (kW)	额定转矩 Torque (Nm)	最大轴负荷 Shaft Load (kg)	主机重量 Weight (kg)	A	B	C	D	E	F	G	H	H1	H2	H3	L	L1	L2	M
WYT-T	0.5AS	450	0.5	φ350	5	φ8	12	4	54	13.6	1.5	270	2500	~300	140	195	47.529	5328	385	420	270	497	540	605	510	580	800	56	30
	1.0AS		7.4					109	27.3	3.1																			
	1.5AS		12					164	41	4.6																			
	1.6AS		12					175	43.7	4.9																			
	1.75AS		12					191	47.7	5.4																			
	0.5BS		0.5					5.2	54	13.6	2.1																		
	1.0BS	1.0	9.6	109	27.3	4.2																							
	1.5BS	1.5	16.3	164	41	6.4																							
	1.6BS	1.6	16.3	175	43.7	6.8																							
	1.75BS	1.75	16.3	191	47.7	7.4																							
	0.5CS	0.5	6.5	54	13.6	2.6																							
	1.0CS	1.0	12.2	109	27.3	5.3																							
	1.5CS	1.5	20.8	164	41	7.9																							
	1.6CS	1.6	20.8	175	43.7	8.4																							
	1.75CS	1.75	20.8	191	47.7	9.2																							
	0.5DS	0.5	7.5	54	13.6	3.2																							
	1.0DS	1.0	14.4	109	27.3	6.4																							
	1.5DS	1.5	25	164	41	9.6																							
	1.6DS	1.6	25	175	43.7	10.3																							
	1.75DS	1.75	25	191	47.7	11.2																							

此系列主机推荐槽型: 单绕V型槽  
Recommended single groove V

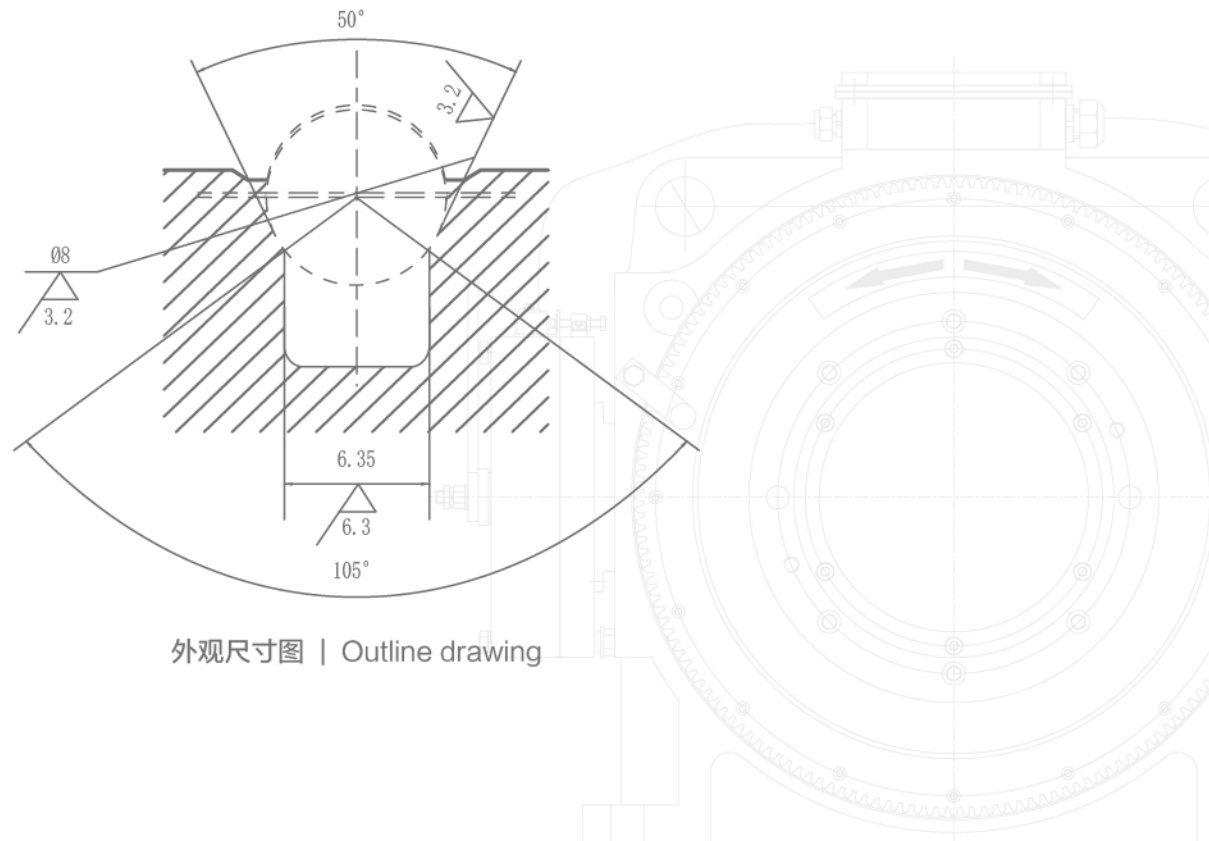

## WYT-T外转子标准系列

### WYT-T Outer Rotor Standard Series

推荐提升高度(Height): ≤90m

型号 Model	规格 Type	载重 Capacity (kg)	轿厢速度 Speed (m/s)	曳引轮直径 Sheave (mm)	槽数 Num	绳径 (mm)	槽间距 Pitch (mm)	安装尺寸 Dimension(mm)																					
								额定电流 Current (A)	额定转速 Motor Speed (rpm)	额定频率 Frequency (Hz)	额定功率 Power (kW)	额定转矩 Torque (Nm)	最大轴负荷 Shaft Load (kg)	主机重量 Weight (kg)	A	B	C	D	E	F	G	H	H1	H2	H3	L	L1	L2	M
WYT-T	0.5A	450	0.5	φ400	4	φ10	16	4.2	48	12	1.6	320	2500	~300	140	195	47.529	5328	385	420	270	497	540	605	510	580	800	56	30
	1.0A		7.7					96	24	3.2																			
	1.5A		12.4					144	36	4.8																			
	1.6A		12.4					153	38.3	5.1																			
	1.75A		12.4					168	42	5.6																			
	2.0A		14.5					192	48	6.4																			
	0.5AL	0.5	4.2	40	9.95	1.6																							
	1.0AL	1.0	7.3	80	19.9	3.2																							
	1.5AL	1.5	12.4	119	29.8	4.8																							
	1.6AL	1.6	12.4	127	31.8	5.1																							
	1.75AL	1.75	12.4	139	34.8	5.6																							
	2.0AL	2.0	13.8	159	39.8	6.4																							
	0.5B	0.5	5.6	48	12	2.3																							
	1.0B	1.0	10.4	96	24	4.6																							
	1.5B	1.5	17.8	144	36	6.9																							
	1.6B	1.6	17.8	153	38.3	7.4																							
	1.75B	1.75	17.8	168	42	8.1																							
	2.0B	2.0	20.2	192	48	9.3																							
	0.5BL	0.5	6.1	40	9.95	2.3																							
	1.0BL	1.0	10.7	80	19.9	4.6																							
	1.5BL	1.5	17.8	119	29.8	6.9																							
	1.6BL	1.6	17.8	127	31.8	7.4																							
	1.75BL	1.75	17.8	139	34.8	8.1																							
	2.0BL	2.0	20	159	39.8	9.2																							
	0.5C	0.5	6.8	48	12	2.8																							
	1.0C	1.0	12.7	96	24	5.5																							
	1.5C	1.5	21.7	144	36	8.3																							
	1.6C	1.6	21.7	153	38.3	8.8																							
	1.75C	1.75	21.7	168	42	9.7																							
	2.0C	2.0	24	192	48	11																							
0.5CL	0.5	6.9	40	9.95	2.8																								
1.0CL	1.0	12.2	80	19.9	5.5																								
1.5CL	1.5	21	119	29.8	8.3																								
1.6CL	1.6	21	127	31.8	8.8																								
1.75CL	1.75	21	139	34.8	9.7																								
2.0CL	2.0	23.8	159	39.8	11																								
0.5D	0.5	7.8	48	12	3.4																								
1.0D	1.0	14.9	96	24	6.7																								
1.5D	1.5	26	144	36	10																								
1.6D	1.6	26	153	38.3	10.7																								
1.75D	1.75	26	168	42	11.7																								
2.0D	2.0	29.6	192	48	13.4																								
0.5DL	0.5	8.4	40	9.95	3.3																								
1.0DL	1.0	14.9	80	19.9	6.7																								
1.5DL	1.5	25.4	119	29.8	10																								
1.6DL	1.6	25.4	127	31.8	10.7																								
1.75DL	1.75	25.4	139	34.8	11.7																								
2.0DL	2.0	28.7	159	39.8	13.3																								
0.5E	0.5	9	48	12	3.85																								
1.0E	1.0	17	96	24	7.7																								
1.5E	1.5	29.3	144	36	11.5																								
1.6E	1.6	29.3	153	38.3	12.3																								
1.75E	1.75	29.3	168	42	13.4																								
2.0E	2.0	32.7	192	48	15.4																								





# WYT-L

## 永磁同步曳引机

### PM Traction Machine

WYT-L系列产品是我司2015年研发的新一代内转子结构的永磁同步曳引机，尤其适用于小机房或无机房。

WYT-L series products is the new generation inner rotor structure PM gearless traction machine developed by BlueLight in 2015. It is suitable for mini machine room or machine roomless elevator application.



#### 主机技术参数 (Parameter of Traction Machine)

额定电压 (Voltage) : AC380V

悬挂比 (Roping) : 2: 1

钢丝绳绕法 (Wrap) : 单绕 (Single)

额定载重量 (Capacity) : 450kg ~ 1275kg

轿厢速度 (Speed) : 0.5m/s ~ 2.0m/s

防护等级 (Protection Grade) : IP41

绝缘等级 (Ins. Class) : F

曳引机极数 (Traction machine pole): 20

启动频次 (次/小时, Stars per hour): 240

工作制 (Rating): S5-40%

推荐提升高度 (Height): ≤80m

#### 制动器技术参数 (Parameter of Brake)

型号 (Model) : BLS

绝缘等级 (Ins. Class) : F

额定电压 (Voltage) : DC110V

额定电流 (Current) : 1.46Ax2

#### 特点 (Features)

- 针对无机房和小机房进行特殊静音设计;
- 针对某些顶层高度不足接线困难的现场可选配提供转接线盒;
- 散热效果好, 效率高;
- 高转矩密度设计, 材料利用率高, 体积小重量轻;
- 电磁结构优化, 低速运行平稳, 过载能力强;
- 采用轴刹制动器, 结构紧凑, 制动噪音低, 响应速度快;
- Special silent design for MMR or MRL.
- Transfer junction box can be provided for small installation height.
- Further improves heat dissipation.
- High efficiency and high torque density design with high material utilization, small size and light weight.
- The inner rotor structure improves electromagnetic structure, result smooth low speed running and high overload capacity.
- Use shaft brake, with the advantage of compact structure, low braking noise and fast response time.

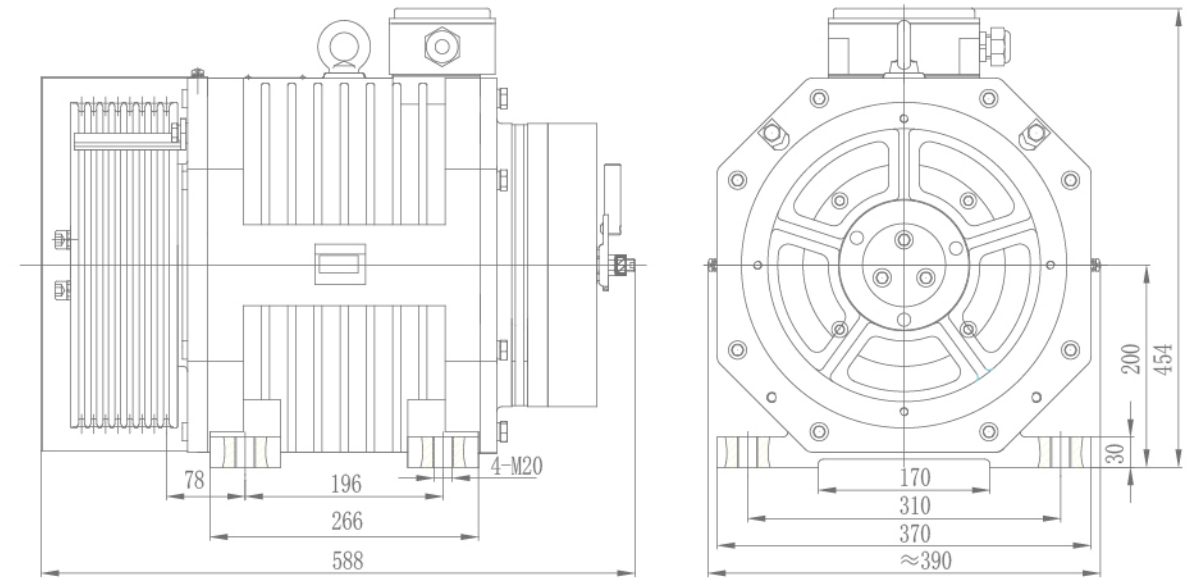

外观尺寸图 | Outline drawing

#### WYT-L内转子系列 WYT-L Inner Rotor Series

系列 Series	型号 Model	载重 Capacity (kg)	轿厢速度 Speed (m/s)	曳引轮直径 Sheave (mm)	槽数 Num	绳径 (mm)	槽间距 Pitch (mm)	额定电流 Current (A)	额定转速 Motor Speed (rpm)	额定频率 Frequency (Hz)	额定功率 Power (kW)	额定转矩 Torque (Nm)	最大轴负荷 Shaft Load (kg)	主机重量 Weight (kg)
WYT-L	C0.5CS	800	0.5	φ240	10	φ6	9	6.3	79	13	2.7	320	4000	270
	C1.0CS		1.0					12.7	159	26.5	5.3			
	C1.5CS		1.5					22.2	238	40	8			
	C1.6CS		1.6					22.2	254	42.3	8.5			
	C1.75CS		1.75					22.2	278	46.3	9.3			
	C2.0CS		2.0					24.8	318	53	10.7			
	C0.5C	800	0.5	φ320	6	φ8	12	6.3	59	9.8	2.7	430	4000	270
	C1.0C		1.0					12.7	119	19.8	5.4			
	C1.5C		1.5					22.2	178	29.7	8			
	C1.6C		1.6					22.2	190	31.7	8.6			
	C1.75C		1.75					22.2	208	34.7	9.4			
	C2.0C		2.0					24.8	239	39.8	10.8			
	C0.5DS	1050	0.5	φ240	10	φ6	9	7.5	79	13	3.3	400	4000	270
	C1.0DS		1.0					15.1	159	26.5	6.7			
	C1.5DS		1.5					26.5	238	40	10			
	C1.6DS		1.6					26.5	254	42.3	10.6			
	C1.75DS		1.75					26.5	278	46.3	11.6			
	C2.0DS		2.0					29	318	53	13.3			
	C0.5D	1050	0.5	φ320	7	φ8	12	7.5	59	9.8	3.3	530	4000	270
	C1.0D		1.0					15.1	119	19.8	6.6			
	C1.5D		1.5					26.5	178	29.7	9.9			
	C1.6D		1.6					26.5	190	31.7	10.5			
	C1.75D		1.75					26.5	208	34.7	11.5			
	C2.0D		2.0					29	239	39.8	13.3			
C0.5E	1150	0.5	φ320	8	φ8	12	8.2	59	9.8	3.6	580	4000	270	
C1.0E		1.0					16.5	119	19.8	7.2				
C1.5E		1.5					29.0	178	29.7	10.8				
C1.6E		1.6					29.0	190	31.7	11.5				
C1.75E		1.75					29.0	208	34.7	12.6				
C2.0E		2.0					31.7	239	39.8	14.5				
C0.5F	1275	0.5	φ320	8	φ8	12	8.9	59	9.8	3.9	630	4000	270	
C1.0F		1.0					17.9	119	19.8	7.9				
C1.5F		1.5					31.5	178	29.7	11.7				
C1.6F		1.6					31.5	190	31.7	12.5				
C1.75F		1.75					31.5	208	34.7	13.7				
C2.0F		2.0					34.5	239	39.8	15.8				

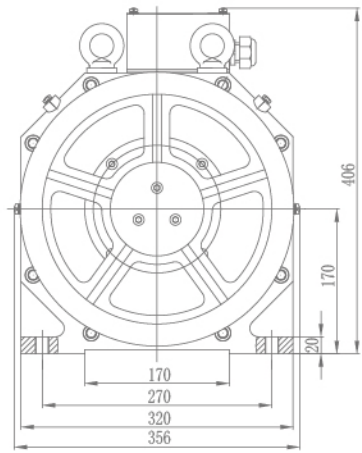
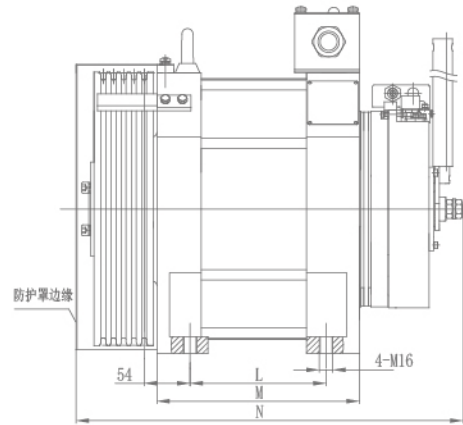

外观尺寸图 | Outline drawing

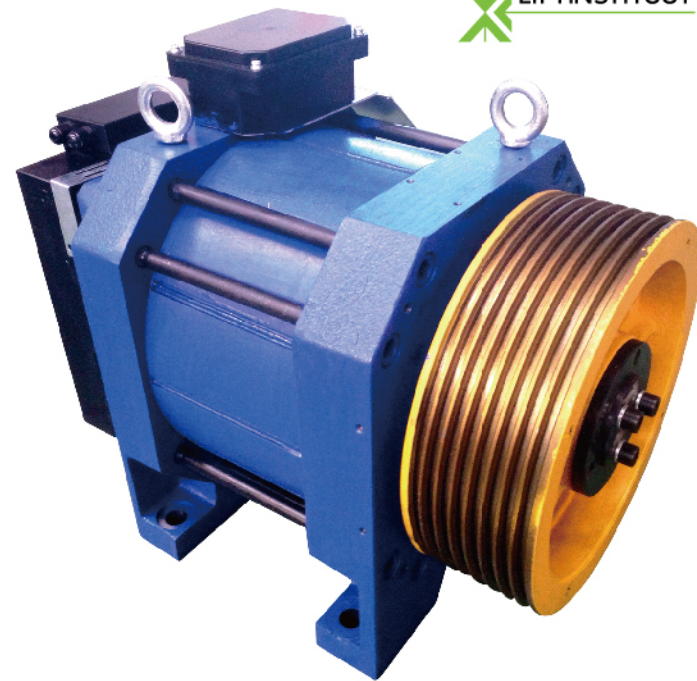

# WYT-F

## 永磁同步曳引机(钢带别墅梯)

### PM Traction Machine(Belt villa)



针对日益增长的家庭电梯市场，蓝光集团开发了WYT-F系列家庭曳引机，使用钢带作为传动介质，配合蓝光集团配套开发的STD32KN系列电梯专用钢带，使电梯舒适感更好，噪音更小。同时曳引机体积小，适合无机房设计，安装维护简单。

Due to increase needs of home (belt villa) elevator, Bluelight group develop WYT-F series belt drive PMS machine. The belt machine can work with Bluelight series (STD32KN) to achieve best lift comfort level with minimum operation noise. This series machine has small size suitable for MRL design and easy maintenance.

#### 主机技术参数 (Parameter of Traction Machine)

额定电压 (Voltage) : AC380V/AC220V  
 悬挂比 (Roping) : 1: 1  
 钢丝绳绕法 (Wrap) : 单绕 (Single)  
 额定载重量 (Capacity) : 400kg  
 轿厢速度 (Speed) : 0.4m/s  
 防护等级 (Protection Grade) : IP41  
 绝缘等级 (Ins. Class) : F  
 曳引机极数 (Traction machine pole): 10  
 启动频次(次/小时, Stars per hour): 150  
 工作制(Rating): S5-40%  
 推荐提升高度(Height): ≤20m

#### 特点 (Features)

- 外壳采用铝合金材质，具有良好的散热性，体积小，重量轻；
- 运行平稳，低速性能好；
- 主机采用轴刹制动器，结构紧凑，制动噪音低。
- Machine is made of aluminum alloy material, with good heat dissipation, small size and light weight;
- Smooth running, excellent performance at low speed;
- Configured with shaft brake of low noise and compact structure.

#### 钢带技术参数 (Parameter of Belt)

型号 (Model) : ECOSTD 32 /43/46 KN  
 宽度 (Width) : 30mm  
 厚度 (Thickness) : 3/3.2/3.3 mm  
 破断拉 (Breaking Force) : 32/43/46kN  
 钢丝绳直径 (WireRope Diameter) : 1.6/1.98/2 mm  
 钢丝绳根数 (Rope Number) : 12/10/10根  
 外层包覆 (Outer Cover) : 热塑性聚氨酯 (Thermoplastic Polyurethane)

#### 制动器技术参数 (Parameter of Brake)

型号 (Model) : BLS  
 绝缘等级 (Ins.Class) : F  
 额定电压 (Voltage) : DC110  
 额定电流 (Current) : 1.1A

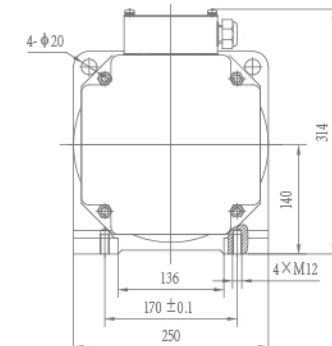
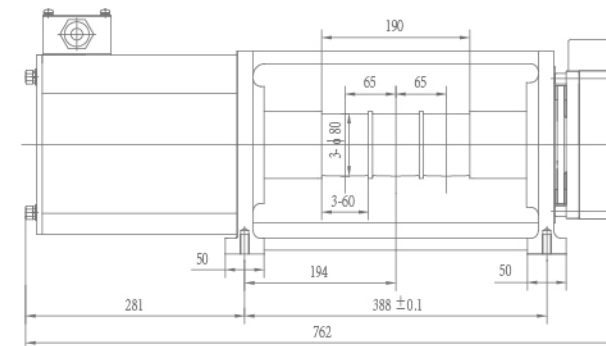

外观尺寸图  
Outline drawing

### WYT-L内转子系列 WYT-L Inner Rotor Series

系列 Series	型号 Model	载重 Capacity (kg)	轿厢速度 Speed (m/s)	曳引轮直径 Sheave (mm)	槽数 Num	绳径 (mm)	槽间距 Pitch (mm)	额定电流 Current (A)	额定转速 Motor Speed (rpm)	额定频率 Frequency (Hz)	额定功率 Power (kW)	额定转矩 Torque (Nm)	最大轴负荷 Shaft Load (kg)	主机重量 Weight (kg)	安装尺寸 Dimension(mm)		
															L	M	N
WYT-L	B0.5AS	450	0.5	φ240	7	φ6	9	3.9	79	13	1.5	180	2000	~150	160	238	455
	B1.0AS		1.0					7.6	159	26.5	3						
	B0.5A	450	0.5	φ320	4	φ8	12	3.9	59	9.8	1.5	240					
	B1.0A		1.0					7.6	119	19.8	3						
	B0.5BS	450	0.5	φ320	4	φ8	12	5.2	79	13	2	240					
	B1.0BS		1.0					10.4	159	26.5	4						
	B1.5BS	630	1.5	φ240	8	φ6	9	16.4	238	40	6	240					
	B1.6BS		1.6					16.4	254	42.3	6.4						
	B1.75BS	630	1.75	φ240	8	φ6	9	16.4	278	46.3	7	240					
	B0.5B		0.5					5.7	59	9.8	2.1						
	B1.0B	630	1.0	φ320	5	φ8	12	10.2	119	19.8	4.2	340					
	B1.5B		1.5					17.3	178	29.7	6.3						
	B1.6B	630	1.6	φ320	5	φ8	12	17.3	190	31.7	6.8	340					
	B1.75B		1.75					17.3	208	34.7	7.4						

### WYT-F内转子系列 WYT-F Inner Rotor Series

系列 Series	型号 Model	载重 Capacity (kg)	轿厢速度 Speed (m/s)	曳引轮直径 Sheave (mm)	槽数 Num	槽宽 (mm)	槽间距 Pitch (mm)	额定电压 Voltage (V)	额定电流 Current (A)	额定转速 Motor Speed (rpm)	额定频率 Frequency (Hz)	额定功率 Power (kW)	额定转矩 Torque (Nm)	最大轴负荷 Shaft Load (kg)	主机重量 Weight (kg)
WYT-F	1V0.4B080	400	0.4	φ80	3	60	65	220 380	6 3.5	96	8	1.1	110	1800	~110



# WYT-U

## 永磁同步曳引机

### PM Traction Machine



WYT-U系列产品是客户专门设计的大扭矩、大载重曳引机，广泛应用于高层建筑中的观光梯、客梯、货梯，医院中的病床梯等。

WYT-U series products are designed with large torque and heavy load capacity. It is widely used in high-rise buildings elevator applications such as panorama elevator, passenger & cargo elevator, hospital bed elevator and else.

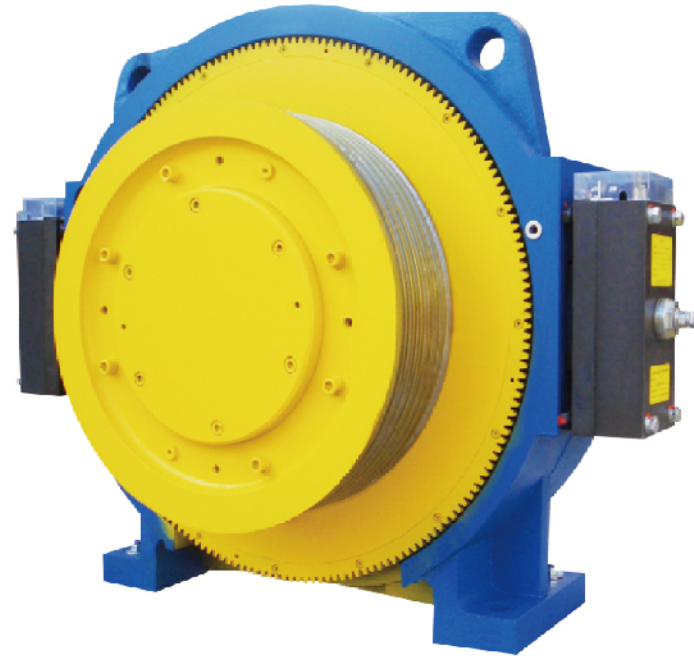

#### 主机技术参数 (Traction Machine Parameter)

额定电压 (Voltage) : AC380V

悬挂比 (Roping) : 2: 1

钢丝绳绕法 (Wrap) : 单绕 (Single)

额定载重量 (Capacity) : 1350kg~2000kg

轿厢速度 (Speed) : 1.0m/s~2.5m/s

防护等级 (Protection Grade) : IP41

绝缘等级 (Ins. Class) : F

曳引机极数(Traction machine pole): 30

启动频次(次/小时, Stars per hour): 240

工作制(Rating): S5-40%

推荐提升高度(Elevator Height): ≤120m

#### 制动器技术参数 (Brake Parameter)

型号 (Model) : BLB

绝缘等级 (Ins.Class) : F

额定电压 (Voltage) : DC110V

额定电流 (Current) :

系列 Series	梯速(m/s) Speed	载重代号 Capacity code	额定电流 Current
WYT-U	1.0~2.5	DS, ES(1350kg~1600kg)	1.3A
		FS(2000kg)	1.6A

#### 特点 (Features)

- 低速运行平稳，效率高，转矩大；
- 采用高性能的永磁材料和完善的磁路结构，使温升和噪音都远远低于行业标准；
- 曳引机采用过热保护装置，设计完善，可靠性高；
- 采用BLB块式制动器，结构简单，制动安全可靠。
- Low-speed operation is smooth, high efficiency, large torque;
- Use high performance permanent magnetic materials and improve the magnetic circuit structure, so that the temperature rise and noise are much lower than industry standard.
- Traction machine use overheating protection device, with extra safety & reliability;
- Use block type armless brake, simple structure with fast response time and high reliability.

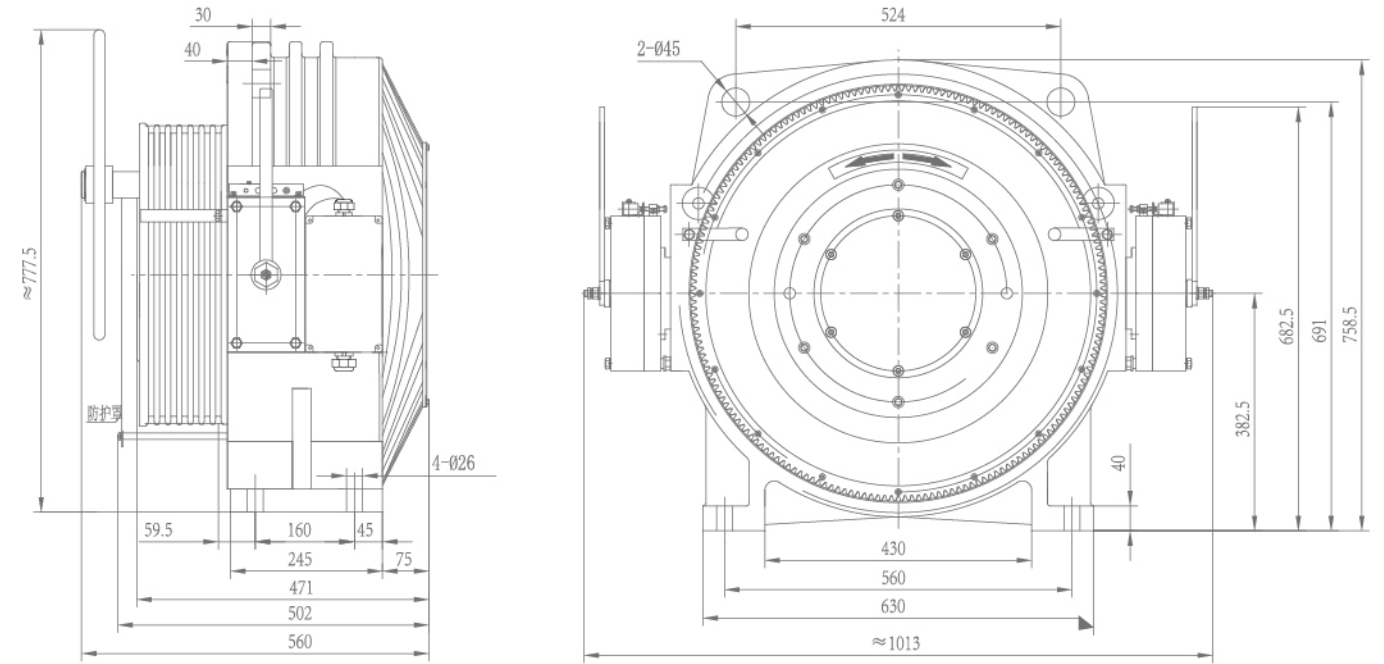

外观尺寸图 | Outline drawing

#### WYT-U外转子系列 WYT-U Outer Rotor Series

系列 Series	型号 Model	载重 Capacity (kg)	轿厢速度 Speed (m/s)	曳引轮直径 Shaave (mm)	槽数 Num	绳径 (mm)	槽间距 Pitch (mm)	额定电流 Current (A)	额定转速 Motor Speed (rpm)	额定频率 Frequency (Hz)	额定功率 Power (kW)	额定转矩 Torque (Nm)	最大轴负荷 Shaft Load (kg)	主机重量 Weight (kg)
WYT-U	1.0DS	1350	1.0	φ480	7	φ12	18	19.5	80	19.9	8.8	1055	7000	~800
	1.75DS		33.7					139	34.8	15.4				
	2.0DS		39.3					159	39.8	17.6				
	2.5DS	47.2	199	49.7	22	1250	7000	~800						
	1.0ES	22.9	80	19.9	10.4									
	1.75ES	40.5	139	34.8	18.2									
	2.0ES	46	159	39.8	20.8									
	2.5ES	57.5	199	49.7	26									
	1.0FS	28.7	80	19.9	13.1									
	1.75FS	50.8	139	34.8	22.9	1570	7000	~800						
	2.0FS	57.6	159	39.8	26.2									
	2.5FS	71.9	199	49.7	32.7									

# WYT-V

## 永磁同步曳引机(1:1悬挂比) PM Traction Machine(1:1 Roping)

WYT-V系列是我公司于2014年推出的高性能无齿轮永磁同步曳引机，主要针对老旧异步机电梯的改造及市场的需求。该类型同步曳引机结构更可靠，性能优异，达到国内领先水平。

WYT-V series is developed by Bluelight in 2014, mainly targeting elevator modernisation project to replace old asynchronous machine.

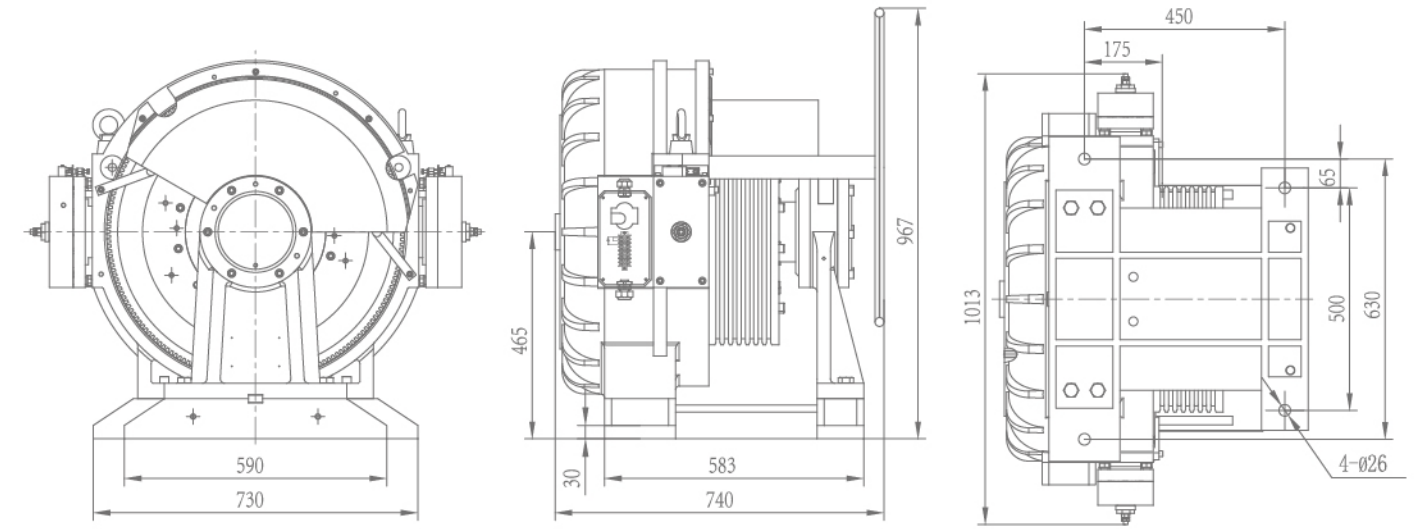

外观尺寸图 | Outline drawing

### 主机技术参数 (Traction Machine Parameter)

- 额定电压 (Voltage) : AC380V
- 悬挂比 (Roping) : 1: 1
- 钢丝绳绕法 (Wrap) : 单绕 (Single)
- 额定载重量 (Capacity) : 1000kg~1250kg
- 轿厢速度 (Speed) : 1.0m/s~2.5m/s
- 防护等级 (Protection Grade) : IP41
- 绝缘等级 (Ins. Class) : F
- 曳引机极数(Traction machine pole): 30
- 启动频次(次/小时, Stars per hour): 240
- 工作制(Rating): S5-40%
- 推荐提升高度(Height): ≤120m

### 制动器技术参数 (Brake Parameter)

- 型号 (Model) : BLB
- 绝缘等级 (Ins.Class) : F
- 额定电压 (Voltage) : DC110V
- 额定电流 (Current) : 1.98A

### 特点 (Features)

- ◎ 双支撑结构设计，结构可靠，轴负荷大；
- ◎ 高效率，高转矩密度；
- ◎ 空载反电势谐波含量小，振动小，运行平稳；
- ◎ 主机散热效果好，温升低。
- ◎ Double support design, reliable mechanical structure with high shaft load;
- ◎ High torque density with high efficiency;
- ◎ Optimized design for winding, lower harmonics, lower noise, low vibration, smooth running;
- ◎ Advanced heat dissipation design, low temperature rise.

### WYT-V外转子系列 WYT-V Outer Rotor Series

系列 Series	型号 Model	载重 Capacity (kg)	轿厢速度 Speed (m/s)	曳引轮直径 Sheave (mm)	槽数 Num	绳径 (mm)	槽间距 Pitch (mm)	额定电流 Current (A)	额定转速 Motor Speed (rpm)	额定频率 Frequency (Hz)	额定功率 Power (kW)	额定转矩 Torque (Nm)	最大轴负荷 Shaft Load (kg)	主机重量 Weight (kg)
WYT-V	1.0BS48	1000	1.0	φ480	10	φ10	16	14.8	40	9.95	6.6	1570	10000	~960
	1.5BS48		1.5					21.8	60	15	9.9			
	1.75BS48		1.75					25.3	70	17.5	11.5			
	2.0BS48		2.0					28.7	80	19.9	13.1			
	2.5BS48	2.5	37	100	25	16.4	1640							
	1.0BS50	1.0	14.8	38	9.5	6.6								
	1.5BS50	1.5	21.8	57	14.3	9.9								
	1.75BS50	1.75	25.3	67	16.7	11.5								
	2.0BS50	2.0	28.7	76	19	13.1	1800							
	2.5BS50	2.5	37	96	24	16.4								
	1.0BCS48	1.0	17	40	9.95	7.5								
	1.5BCS48	1.5	25.2	60	15	11.3								
	1.75BCS48	1.75	29.4	70	17.5	13.2	1880							
	2.0BCS48	2.0	33.3	80	19.9	15								
	2.5BCS48	2.5	41.8	100	25	18.8								
	1.0BCS50	1.0	17	38	9.5	7.5								
	1.5BCS50	1.5	25.2	57	14.3	11.3	1940							
	1.75BCS50	1.75	29.4	67	16.7	13.2								
	2.0BCS50	2.0	33.3	76	19	15								
	2.5BCS50	2.5	41.8	96	24	18.8								
1.0CS48	1.0	1250	1.0	φ480	10	φ10	16	19	40	9.95	8	2020		
1.5CS48	1.5		27.8					60	15	12.1				
1.75CS48	1.75		32					70	17.5	14.2				
2.0CS48	2.0		36.6					80	19.9	16.1				
2.5CS48	2.5	45.5	100	25	20.3	2020								
1.0CS50	1.0	19	38	9.5	8									
1.5CS50	1.5	27.8	57	14.3	12.1									
1.75CS50	1.75	32	67	16.7	14.2									
2.0CS50	2.0	36.6	76	19	16.1	2020								
2.5CS50	2.5	45.5	96	24	20.3									



# WYT-H

## 永磁同步曳引机

### PM Traction Machine

WYT-H系列主机是我公司推出的高性能大转矩超高速无齿轮永磁同步曳引机，适合超高层建筑电梯使用。经过不断的电磁及机械结构的优化，主机性能达到国际先进水平。

WYT-H series ultra-high speed PM gearless traction machine is developed by Bluelight in 2012 to target skyscrapers with ultra-high speed elevator (up to 8m/s).

#### 主机技术参数 (Traction Machine Parameter)

- 额定电压 (Voltage) : AC380V
- 悬挂比 (Roping) : 1: 1
- 钢丝绳绕法 (Wrap) : 复绕 (Double)
- 额定载重量 (Capacity) : 1600kg
- 轿厢速度 (Speed) : 5m/s ~ 8m/s
- 防护等级 (Protection Grade) : IP41
- 绝缘等级 (Ins. Class) : H
- 曳引机极数 (Traction machine pole): 30
- 启动频次(次/小时, Stars per hour): 240
- 工作制(Rating): S5-40%
- 推荐提升高度(Elevator Height): ≤360m



#### 制动器技术参数 (Brake Parameter)

- 型号 (Model) : EC-4026EF-100
- 绝缘等级 (Ins.Class) : F
- 额定电压 (Voltage) : DC90/40V
- 额定电流 (Current) : 4.7/2.1A

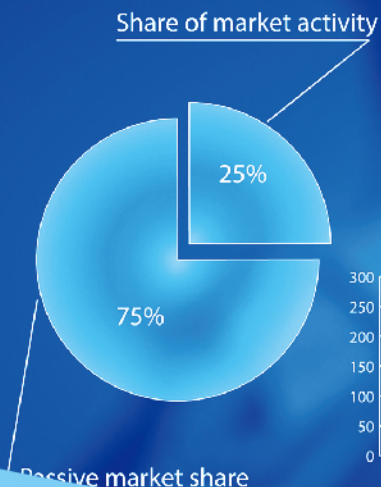

Changes in the activity of the active and passive market is uncertain. Established positive trends in various market segments.

Projected sales of main products in 2013

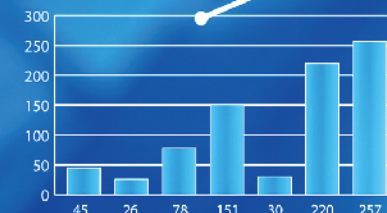

#### 特点 (Features)

- 超大轴负荷设计,超高速设计;
- 优化的绕组使曳引机振动小,噪音低,损耗分布合理,精细的风冷散热设计,温升低;
- 原装进口碟刹制动器,制动系统安全可靠;

- Extra high shaft load design, suitable for ultra-high speed operation;
- Optimized winding design, less harmonic content, loss distribution optimization, fan cooling system with low temperature rise;
- Use SUNTES disk brake system, high reliability.

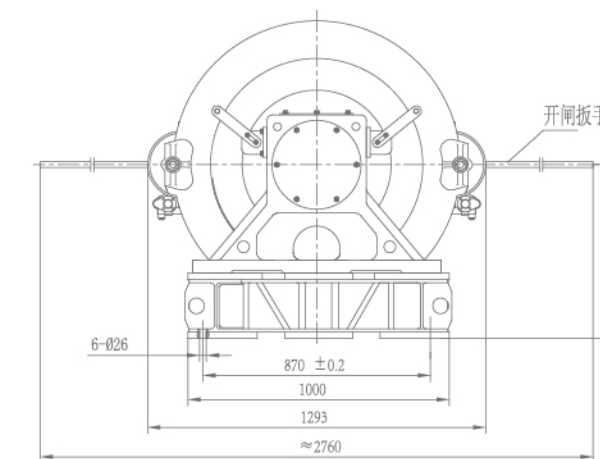
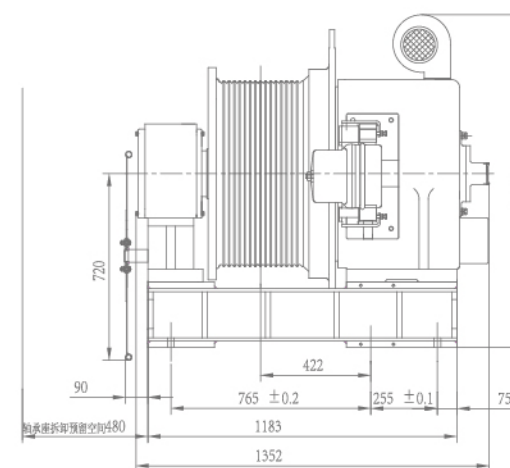

外观尺寸图 | Outline drawing

#### WYT-H外转子系列 WYT-H Outer Rotor Series

系列 Series	型号 Model	载重 Capacity (kg)	轿厢速度 Speed (m/s)	曳引轮直径 Sheave (mm)	槽数 Num	绳径 (mm)	槽间距 Pitch (mm)	额定电流 Current (A)	额定转速 Motor Speed (rpm)	额定频率 Frequency (Hz)	额定功率 Power (kW)	额定转矩 Torque (Nm)	最大轴负荷 Shaft Load (kg)	主机重量 Weight (kg)
WYT-H	5.0E1	1600	5.0	φ 710	16	φ 16	20	111.4	134	33.6	51	3626	35000	≈ 3500
	6.0E1		6.0					135.3	161	40.3	61.2			
	7.0E1		7.0					158	188	47.1	71.5			
	8.0E1		8.0					172.7	215	53.8	81.7			







## WYT-Y内转子系列 (复绕系列) WYT-Y Inner Rotor Series (Double Wrap)

系列 Series	型号 Model	载重 Capacity (kg)	轿厢速度 Speed (m/s)	曳引轮直径 Sheave (mm)	槽数 Num	绳径 (mm)	槽间距 Pitch (mm)	额定电流 Current (A)	额定转速 Motor Speed (rpm)	额定频率 Frequency (Hz)	额定功率 Power (kW)	额定转矩 Torque (Nm)	最大轴负荷 Shaft Load (kg)	主机重量 Weight (kg)	安装尺寸 Dimension(mm)													
															A	B	C	D	E	F	H	K	L	M	N			
WYT-Y	1.0A2	800	1.0	φ410	8	φ10	14	14	94	15.7	5.7	580	10000	≈850	340	510	610	730	300	260	960	78	495	575	970			
	1.6A2		1.6					20.8	150	25	9.1																	
	1.75A2		1.75					22.9	163	27.2	9.9																	
	2.0A2		2.0					25.5	186	31	11.3																	
	2.5A2		2.5					31.5	234	39	14.1																	
	3.0A2	3.0	37.3	239	39.84	17																						
	4.0A2	4.0	49.1	318	53	22.6																						
	1.0B2	1.0	1000	1.0	φ410	10	φ10	14	16.1	94	15.7	6.7	682	10000	≈850	340	510	610	730	300	260	960	78	495	575	970		
	1.6B2	1.6		24.5					150	25	10.7																	
	1.75B2	1.75		26.3					163	27.2	11.7																	
	2.0B2	2.0		29.6					186	31	13.3																	
	2.5B2	2.5		37.5					234	39	16.7																	
	3.0B2	3.0	44.4	239	39.84	20																						
	4.0B2	4.0	58.6	318	53	26.7																						
	1.0C2	1.0	1275	1.0	φ480	10	φ12	15	22.4	80	13.34	8.5	1020	12000	≈1300	400	570	670	875	330	320	1050	68	495	575	990		
	1.6C2	1.6		33.6					127	21.2	13.6																	
	1.75C2	1.75		36.5					139	23.2	14.8																	
	2.0C2	2.0		41.5					159	26.5	17																	
	2.5C2	2.5		51.4					199	33.2	21.3																	
	3.0C2	3.0	60.3	239	39.84	25.5																						
	4.0C2	4.0	79.5	318	53	34																						
	1.0D2	1.0	1350	1.0	φ480	10	φ12	15	25	80	13.34	9.5	1140	12000	≈1300	400	570	670	875	330	320	1050	68	495	575	990		
	1.6D2	1.6		37.6					127	21.2	15.2																	
	1.75D2	1.75		40.8					139	23.2	16.6																	
	2.0D2	2.0		46.4					159	26.5	19																	
	2.5D2	2.5		57.4					199	33.2	23.8																	
	3.0D2	3.0	67.4	239	39.84	28.5																						
	4.0D2	4.0	89	318	53	38																						
	1.0E2	1.0	1600	1.0	φ480	10	φ12	15	27	80	13.34	11.1	1330	12000	≈1300	400	570	670	875	330	320	1050	68	495	575	990		
	1.6E2	1.6		41					127	21.2	17.7																	
	1.75E2	1.75		45.8					139	23.2	19.4																	
	2.0E2	2.0		51					159	26.5	22.2																	
	2.5E2	2.5		63.8					199	33.2	27.7																	
	3.0E2	3.0	74.6	239	39.84	33.3																						
	4.0E2	4.0	99.6	318	53	44.3																						
	1.0EF2	1.0	1800	1.0	φ480	12	φ12	15	29.7	80	13.34	12.5	1490	12000	≈1300	400	570	670	875	330	320	1050	68	495	575	990		
	1.6EF2	1.6		45.8					127	21.2	19.8																	
	1.75EF2	1.75		49.6					139	23.2	21.7																	
	2.0EF2	2.0		55.8					159	26.5	24.8																	
	2.5EF2	2.5		71.5					199	33.2	31																	
3.0EF2	3.0	85.2	239	39.84	37.3																							
4.0EF2	4.0	112	318	53	49.6																							
1.0F2	1.0	2000	1.0	φ480	12	φ12	15	34	80	13.34	13.8	1650	12000	≈1300	400	570	670	875	330	320	1050	68	495	575	990			
1.6F2	1.6		53					127	21.2	22																		
1.75F2	1.75		54.9					139	23.2	24																		
2.0F2	2.0		63.5					159	26.5	27.5																		
2.5F2	2.5		80					199	33.2	34.4																		
3.0F2	3.0	92	239	39.84	41.3																							
4.0F2	4.0	123	318	53	54.9																							

## 绳槽参数 THE PARAMETER LIST OF GROOVE

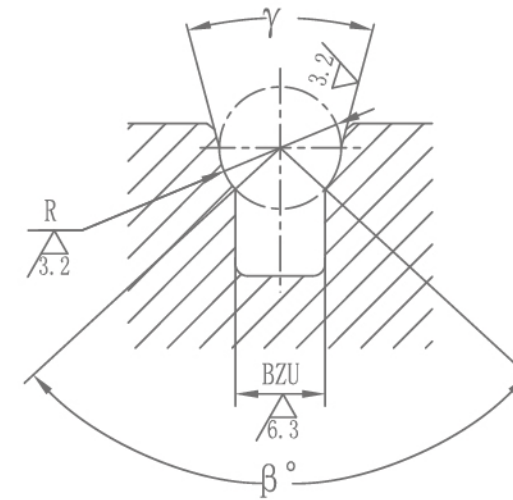

单绕槽型  
(Single groove)

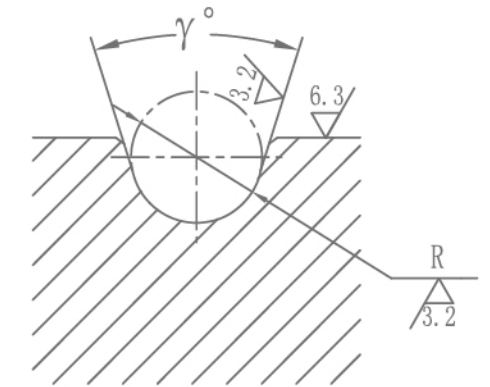

复绕槽型  
(Double groove)

槽型 (Groove)	R	β	γ	BZU
单绕槽型 (Single groove)	φ6	90°	35°	4.24
	φ8	90°	35°	5.66
	φ10	97°	25°	7.49
	φ12	95°	35°	8.85
复绕槽型 (Double groove)	φ10		35°	
	φ12		35°	
	φ16		35°	

# 智慧与力量 COMPANY QUALIFICATION

1. 特种设备型式实验合格证 | Type-examination Certificate of Special Equipment
2. 中华人民共和国专利证书 | Patent certificate
3. 国家高新技术企业认证 | National high-tech enterprise
4. 全国发明展览会银奖 | China Invention Exhibition

5. 质量管理体系认证 | ISO9001
6. 韩国KTL认证KC证书 | KTL Issue KC Certification
7. TUV认证CE证书 | TUV Issue CE Certification



1



2



3



4



5

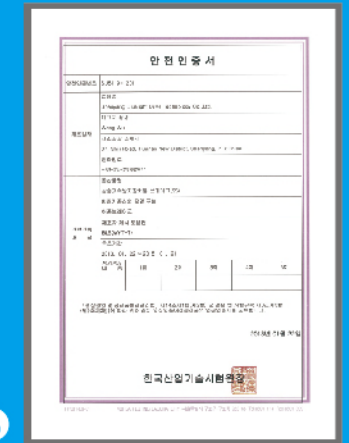

6

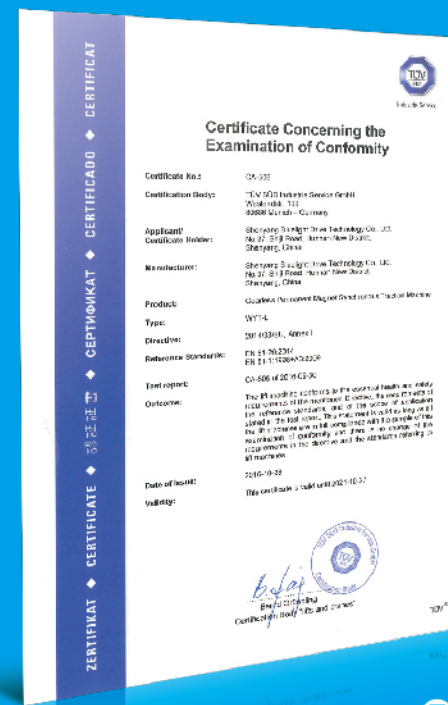
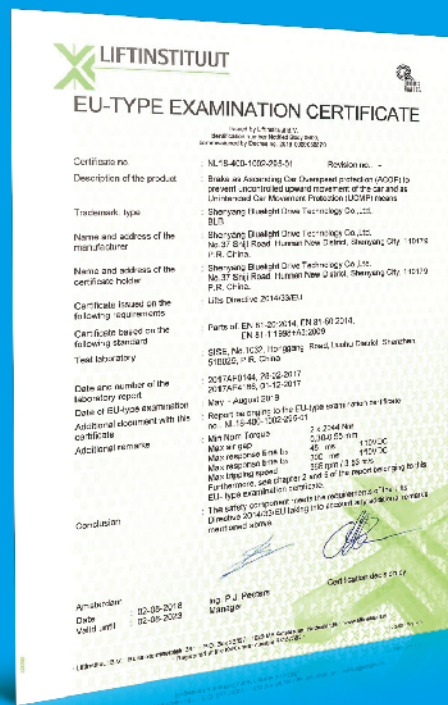

7